

Operating Manual

Auto Locking Glider Models:

100-20 AL

100-15 AL

100-10 AL



Register your warranty online at www.brodaseating.com

Distributor/Rep: This manual must be given to the caregiver responsible for this chair and its occupant.

Caregiver: Before using this chair, read this manual thoroughly and save for future reference.

Contents

FOREWORD	1
GENERAL INFORMATION	2
1 DEFINITIONS	3
2 SAFETY REQUIREMENTS	4
2.1 Training	4
2.2 Application	4
2.3 Shipping and Storage	4
2.4 Pre-Service Check	5
2.5 Hazards	5
2.5.1 Location of Chair - “Danger of Tipping or Falling Objects”	5
2.5.2 Transport Wheels - “Danger of Tipping”	5
2.5.3 Re-Positioning of Resident - “Danger of Clamping”	5
2.5.4 Unintended Movement - “Danger of Falling or Collision”	5
2.5.5 Resident Clothing - “Risk of Injury to Resident’s Skin”	5
2.6 Improper Use	
2.7 Cleaning	6
2.8 Maintenance	7
2.9 Resident Specific Instructions	8
3 OPERATION AND MOVEMENT	9
3.1 Gliding Motion (Auto Lock)	9
3.2 Caregiver Lock	9
3.3 Height Adjustable Armrests	10
3.4 Transport Wheels	10
3.5 Accessories (Options)	10
4 INSPECTION AND FUNCTIONAL TESTING	11
4.1 Inspection	11
4.2 Functional Testing	11
5 TECHNICAL INFORMATION	12
5.1 Specifications	12
5.2 Labels	13
5.3 BRODA Seating Auto Locking Glider Parts Schematic Drawing and Legend	14
6 WARRANTY	15

FOREWORD

Congratulations on your purchase of a BRODA chair and thank you for your confidence in our company and products.

BRODA assumes a leadership role in providing optimum re-positioning functions and mobility for residents of long-term care institutions. Our chairs do not look like traditional chairs and offer advantages unique to BRODA. We are sure that after using your BRODA chair, you will be convinced that your resident's quality of life will be greatly enhanced.

This manual will assist you in making the best use of the capabilities of your BRODA chair and will ensure that you quickly become familiar with its operation.

After reading this manual, if you have any questions about the safe and effective operation of your BRODA chair or accessories contact your local BRODA representative or our Head Office Customer Service personnel for further assistance.

Head Office:

BRODA Seating

560 Bingemans Centre Drive

Kitchener, Ontario Canada N2B 3X9

Phone: (519) 746-8080 Toll Free Can/US: 1-800-668-0637

Fax: (519) 746-8616

E-mail: sales@brodaseating.com

URL: www.brodaseating.com www.seatingisbelieving.com

GENERAL INFORMATION

This document provides guidance on the safe and effective operation of the BRODA chair.

Information in this manual must be followed at all times.

Anyone involved with the operation or maintenance of the BRODA chair, including the resident's family members, must read this operating manual before using the chair.

The resident's primary caregiver is responsible for ensuring that anyone who is unfamiliar with, unwilling, or unable to adhere to the safety and operating instructions, is not permitted to operate or move the chair.

A copy of this instruction manual must always be available.

BRODA accepts no liability for damages, injury or accidents caused by operating errors, improper maintenance, or disregard of the instructions in this manual, including any resident specific instructions.

BRODA reserves the right to make changes to the specifications, dimensions, functions, or components of its products without notice. Product representations in this manual may vary from delivered products.

Each BRODA chair has a unique identifying serial number that must be maintained on the chair as well as with any equipment records.

1 DEFINITIONS

“BRODA” means BRODA Enterprises Inc. doing business as BRODA Seating.

“BRODA chair” refers to Auto Locking Glider, Models 100-20 AL, 100-15 AL, 100-10 AL

“Long-Term Care Institution” refers to a nursing home, hospital, or other healthcare facility that provides health and personal care to its residents on a long-term basis.

“Resident” refers to an individual living in a long-term care institution under the care of professional caregivers.

“Professional Caregiver” refers to doctors, nurses, therapists, nursing aids, healthcare aids, and other specialists who work in a long-term care institution and provide health and personal care to its residents.

“Caregiver” refers to any person in a long-term care institution who is appropriately trained to provide care or services to the resident or the chair used by the resident and may include the resident’s family members or guardian.

“Transfer(s)” refers to the movement of a resident into or out of the chair with the assistance of their caregiver(s).

“Mechanical Transfer(s)” refers to the movement of a resident into or out of the chair with the assistance of their caregiver(s) using a patient lift or other assistive device that bears the weight of the resident.

2 SAFETY REQUIREMENTS

2.1 Training

Before the chair is put into service, this manual must be read thoroughly by the caregiver(s) directly responsible for the resident's care.

After the chair is put into service, this manual must be read thoroughly by any new caregivers prior to operating or moving the chair.

For the purpose of this manual, a resident's family member who shares responsibility for their care is considered a caregiver and is subject to the same competency before being permitted by the resident's primary caregiver to operate or move the chair.

Prior to first use, the customer must arrange for an in-service on the operation and safety requirements in this manual, must be given to the resident's caregivers by the local BRODA representative who supplied the chair.

The primary caregiver must maintain a list of caregivers who have read this manual and who they have authorized to operate and move the chair.

The resident's primary caregiver is responsible for ensuring that anyone who is unfamiliar with, unwilling, or unable to adhere to the safety and operating instructions, is not permitted to operate or move the chair.

The operations of the chair must be performed by the resident's primary caregiver who is responsible for seating. All The operations and adjustments performed should be done in a manner to ensure the overall safety, comfort and well-being of the resident, caregiver and third party. All operations and adjustments required for the resident should be determined by the resident's primary caregiver who is responsible for seating.

2.2 Application

BRODA chairs are intended exclusively for residents of long-term care institutions who are under the care of professional caregivers. The suitability of a BRODA chair must be determined by a qualified caregiver who is familiar with the seating needs of the intended resident. Any other use of the chair is excluded from possible liability claims.

The Auto Locking Glider is not to be used in the shower. The frame and components will rust, and will void the warranty.

The chairs are not explosion resistant and must not be used where there are flammable gases or liquids present (e.g., anesthetics, volatile solvents and cleaners, etc.)

BRODA chairs are designed for use with specific BRODA parts and accessories. The use of non-BRODA parts or accessories with a BRODA will void the warranty and is excluded from possible liability claims.

BRODA chairs may only be used as described in this manual and with proper regard for recognized healthcare and workplace safety and accident prevention practices.

2.3 Shipping and Storage

BRODA chairs should be shipped and stored in an upright position and not stacked higher than 3 boxes. No other materials should be shipped or stored on top of a BRODA box. BRODA boxes should not be placed on pallets.

BRODA chairs should be shipped and stored at temperatures between -20°C and 40°C. BRODA chairs should not be used until they are between 0°C and 30°C.

BRODA chairs should be kept in a clean, dry environment. Do not leave BRODA chairs outdoors as it may cause the paint to peel.

Upon receipt, the shipping carton must be immediately examined for damage. Any damage should be noted on the delivery receipt and a request for inspection by the transportation company should be made. Next, the shipping carton should be opened and the chair must be examined for concealed shipping damage. If the chair appears to be damaged, do not use the chair. File a concealed damage report with the transportation company.

2.4 Pre-Service Check

BRODA chairs are delivered fully assembled. If the chair does not appear to be ready to use upon receipt, immediately contact your supplier and do not put the chair into service until any concerns have been resolved.

Visually inspect the chair for damage, missing parts, and loose fasteners prior to testing the chair's functions. Functional testing must be successfully completed after visual inspection and before use. These obligations apply to the chair's first use and to all subsequent uses (Section 4: Inspection and Functional Testing).

2.5 Hazards

2.5.1 Location of Chair - "Danger of Tipping or Falling Objects"

We recommend that when a resident has been moved to their destination, the chair is placed where the resident cannot reach handrails or other objects, fixed or movable. This is to prevent the resident from pulling the chair over or pulling themselves off the seating surface and to prevent the resident from pulling movable objects onto the chair and themselves.

We recommend that the chair be used in a supervised area to prevent untrained residents, caregivers, or third parties from unauthorized operation, movement, or unsafe actions such as sitting or leaning on the reclined back, elevated footrest, or the armrests. These actions, if not prevented, put the chair at risk of tipping or damage to the chair.

We recommend that a chair only be located on a level surface to minimize the risk of tipping over.

2.5.2 Transport Wheels - "Danger of Tipping"

The transport wheels found on the rear of the Auto Locking Glider chair are for ease of transporting an unoccupied chair. Do not transport the Auto Locking Glider chair while it is occupied. Doing so could cause the chair to tip, causing serious injury to the resident, caregiver or third party.

2.5.3 Re-Positioning of Resident - "Danger of Clamping"

The Auto Locking Glider offers the benefits of height adjustable arms. Before movement of the arm height, ensure the residents' and caregivers' body are clear of all pinch points.

2.5.4 Unintended Movement - "Danger of Falling or Collision"

We recommend BRODA chairs for indoor use within a long-term care institution and where there is not enough slope to cause the chairs to move unaided. Chairs used where the surface is uneven or sloped are at risk of unintended movement and could become a serious danger to the resident, caregiver(s), or a third party. We recommend that BRODA chairs are located away from stairwells, elevators, and exterior doorways within a long-term care institution.

2.5.5 Resident Clothing - "Risk of Injury to Resident's Skin"

We recommend that residents only be seated while they are fully dressed in clothing that meets the needs of their specific condition. Direct contact of bare skin on the straps or vinyl over a period of time could cause moisture on the resident, and/or cause the skin to stick to the straps or vinyl. Prior to the operation or movement of a chair with a covering, the caregiver must ensure any covering placed on the chair does not come into contact with any moving parts and is securely placed, so not to slip.

2.6 Improper Use

As outlined, the improper use of the chair is dangerous to the resident, caregivers, or third parties, and can consist of, but is not limited to the following:

- 1) Unauthorized operation of the chair's functions.
- 2) Unauthorized movement of the chair.
- 3) Inappropriate use of the chair for a resident who has not been assessed by a qualified caregiver responsible for their seating.
- 4) Attempting to operate of multiple chair functions simultaneously by one or more caregivers.
- 5) Attempting to move the chair while occupied by a resident.
- 6) Leaving the resident unattended in the chair near other objects.
- 7) Leaving an agitated resident in the chair in an unsupervised area.
- 8) Leaving a resident unattended.
- 9) Leaving a resident in a chair on a sloping surface.
- 10) Leaving a chair unattended on a sloping surface.
- 11) Using non-BRODA accessories on the chair.
- 12) Using the chair at temperatures below 0°C.
- 13) Using the chair as a shower or bathing chair.
- 14) Using the chair for any use other than its intended purpose.

2.7 Cleaning

BRODA chairs should be wiped clean with soap and water. Diluted household strength ammonia or chlorine based cleaner, as well as a hospital grade cleaner may be used if necessary.

Refer to the following guide for cleaning certain staining agents (Applies to the Permablok3® vinyl, as per the vinyl manufacturer's recommendations) The frame and components of the chair can be cleaned using the same procedure as the vinyl.

The steps below are also located in the Cleaning Guide found on the back of the Broda chair.

Staining Agent	Cleaning Procedure
Eye Shadow / Mascara	Step 1
Grease / Suntan Lotion / Chocolate	Step 1
Blood / Bodily Fluids	Step 2
Red Lipstick	Step 2
Oil Base Paint / Tar / Asphalt	Step 3
Other Tough Stains	Step 4 or 5*

Step 1: Remove excess spill with a damp cloth. Clean with a 1:1 mix of Ivory® liquid and water. Rinse with clean water and dry.

Step 2: Use a straight application of concentrated cleaners such as Formula 409® or Fantastik® Spray Cleaner. Then wipe with a clean cloth. If using a hospital grade cleaner, follow the diluting instructions on the label.

Step 3: Use a 1:1 mix of ammonia and water or a 1:4 mix of bleach and water. Rinse with clean water and dry.

Step 4: Use a straight application of naphtha (lighter fluid). Rinse thoroughly with clean water and pat surface dry.

Step 5: Use a 1:1 mix of isopropyl alcohol and water. If the stain persists, use straight alcohol. Rinse thoroughly with clean water and pat dry. If the stain remains, use a 1:1 mix of acetone and water. Rinse with clean water and pat surface dry.

***Note:** for cleaning that requires steps 4 or 5 – Use a soft cotton cloth saturated with the cleaning material and rub the stain in circles 10 times. Pat dry with another soft cotton cloth, and check results.

Thoroughly clean all removable parts and padding, as well as the frame and components.

BRODA chairs should not be cleaned with petroleum based cleaners. Any petroleum based products that come in contact with any vinyl surface should be removed as quickly as possible. Petroleum based products make vinyl

brittle and will damage the seating surface and cushions. Metal parts and cushions should be wiped completely dry after cleaning. Do not launder vinyl padding.

Do not allow the chair to air dry. Leaving the chair to air dry and not ensuring the entire chair is completely dry may cause the frame and components to rust. Solvents such as those found in spray lubricants should not be used on BRODA Chairs as they can damage moving parts.

Frequency and method of cleaning the chairs should be determined by facility infection control protocols. If visibly soiled, thoroughly clean the chair immediately as per the cleaning instructions in this manual.

The cleaning instructions in this manual are guidelines only. Results may vary under actual conditions. The information does not relieve the user of proper and safe use of the product and all cleaning agents and consideration for the overall cleaning maintenance of the chair. Cleaning and care instructions must be followed in conjunction with facility infection control protocols.

BRODA will not accept warranty or liability claims on chairs that have not been cleaned according to the instructions or cared for in proper regard for patient, caregiver and third party safety and hygiene. The use of certain agents may be harmful to the surface appearance and lifespan of the vinyl. BRODA assumes no responsibility resulting from the use of such cleaning agents to the vinyl.

Touch up paint is available for the powder coated frame. Please call Broda's Customer Service Department if touch up paint is required. Do not leave BRODA chairs outdoors as the frame is not UV protected. Leaving the chairs outdoors could cause the paint to peel.

Formula 409® is a trademark of the Clorox Company.

Fantastik™® is a trademark of DowBrands, Inc.

Trademark of the Dow Chemical Company

Ivory® is a trademark of Proctor and Gamble

2.8 Maintenance

The maintenance on a BRODA chair will vary with the amount of use and the condition of the resident using the chair.

In regular use, after the initial inspection and functional testing, the chair should be inspected and tested bimonthly. We recommend visually inspecting for signs of wear, damage, loose or missing fasteners, and other safety concerns. Periodic testing of chair functions is also necessary. If a breakage, defect, or operational problem is detected, the chair must be successfully repaired, inspected and tested for function before it is returned to service.

The chair should be inspected and tested as often as each use if the chair is used by:

- 1) Aggressive or agitated residents.
- 2) Residents who have involuntary movements.
- 3) Residents weighing over 220 lbs.
- 4) A facility with irregular or sloped surfaces.
- 5) Any unauthorized person.

Do not use lubricants that contain solvents. Solvents may compromise any rubber components on the chair. If necessary, white food grade grease or lubricant can be used on any sliding components.

3 OPERATION AND MOVEMENT

Safety measures as described in Section 1 must be observed when operating the chair's functions or moving the chair. Only authorized caregivers should attempt to operate or move a chair. The caregiver must use proper body mechanics when operating the chair, and be prepared to support the weight of the resident while operating the chair.

3.1 Gliding Motion (Auto Lock)

The Glider has an auto-locking mechanism that aids in resident safety. The mechanism allows the gliding to be activated only once the resident sits in the chair, and become locked/de-activated once the resident begins to stand up from the chair.



3.2 Caregiver Lock

The Glider has a caregiver lock that prevents any unwanted gliding. The lock is located at the rear of the chair.

WARNING: Only apply the caregiver lock when the chair is unoccupied.

To Lock and Unlock the Caregiver Lock:

- Pull the handle.
- Turn approximately a quarter turn and insert the tab into the slot for locking, or release the tab for unlocking.

WARNING: Do not place fingers near tab as this could cause pinching.

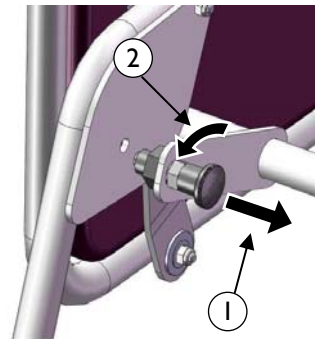

3.3 Height Adjustable Armrests

The armrest height can easily be adjusted in order to accommodate various residents. The armrest height should be adjusted to provide correct arm support for the resident as determined by the caregiver.

To Adjust the Armrest Height:

-Squeeze the pins together which are located under the armrest flap.

WARNING: DO NOT place fingers at the top of the pins as this could cause pinching. Place fingers in the concave shape of the pins.

-Raise or lower the arm to the desired height.

WARNING: DO NOT place fingers anywhere underneath the arm while adjusting, as this could cause pinching. Upon releasing the pins the armrest height will lock into place.

Secure the outside flap on the side panel. Change the height on the other arm as desired.

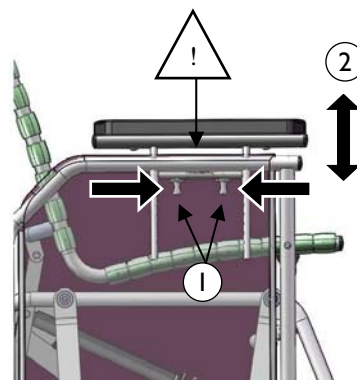

3.4 Transport Wheels

The Auto Locking Glider has two rear transport wheels for ease of transporting the chair.

To Transport the Chair:

-Apply the caregiver lock.

-Standing directly behind the chair, tilt the chair back onto the transport wheels and transport to the desired location.

-Once the chair is in the desired location and in the upright position, the caregiver lock may be released if desired.

WARNING: Do not transport the chair while it is occupied.

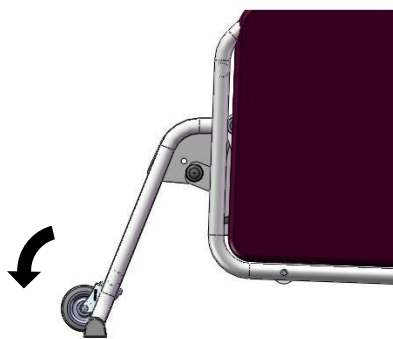

3.5 Accessories (Options)

We recommend BRODA accessories for use only on BRODA chairs. The correct installation of the BRODA accessory is very important. We recommend that the BRODA chair is ordered with the required accessories already installed. Only authorized caregivers who thoroughly understand the accessory installation procedures should attempt to install their BRODA accessories without assistance from their local BRODA representative. BRODA does not recommend use of other manufacturer's accessories on BRODA chairs.

4 INSPECTION AND FUNCTIONAL TESTING

Safety measures as described in Section 1 must be observed when inspecting or testing a chair. Only authorized caregivers or maintenance staff should attempt to inspect or test a chair.

4.1 Inspection

We recommend regular visual inspection for signs of wear, damage, loose or missing fittings, and other safety concerns. If a breakage, defect, or operational problem is detected, the chair must be repaired inspected and tested for function before it is returned to service.

We recommend that the chair be inspected as often as each use if there is any reason to be concerned about the possibility of increased wear or loose or missing fittings. **At a minimum, in regular use the chair should be inspected on a bimonthly basis.** The visual inspection procedure should include at least the observation of all the fittings (fasteners):

The visual inspection procedure should include at least the observation of the following parts:

- 1) The cylinder that assists the auto lock gliding
- 2) The vinyl straps used in the seat and back
- 3) The cushions
- 4) The caregiver lock and pin that engages the locking plate
- 5) The armrest height adjustment pins

The visual inspection procedure should include the observation of any installed accessories. The visual inspection should be performed by the facility, or if in a private residence, by the individual responsible for the chair.

4.2 Functional Testing

We recommend that the chair should be tested for operation of the chair's functions without a resident in the chair. The testing may be as often as each use if there is any reason to be concerned about the possibility of increased wear or damage to the chair's components. At a minimum, in regular use the chair should be tested for functions as described in Section 3.

If the caregiver or maintenance department performing the functional testing believes that any function is not operating correctly, the chair should be taken out of service until a satisfactory functional test can be completed.

When performing repairs or maintenance, do not use lubricants that contain solvents. Solvents will damage many of the moving components in the chair. If necessary, a white, food grade grease (lubricant) may be used on the sliding components in the chair. Do not use spray lubricants on any part of the chair.

5 TECHNICAL INFORMATION

5.1 Specifications

Specifications for Auto Locking Glider Models 100-20 AL, 100-15 AL, 100-10 AL



1. Gliding: Smooth, gliding action with auto lock feature. Gliding is activated once user sits in chair, and is locked/de-activated once user begins to stand from chair.
2. Caregiver Lock Caregiver lock can be activated to prevent unwanted gliding.
3. Frame: 16 gauge powder coated tubular steel
4. Seat/Back Surface: BRODA Comfort Tension Seating™ Strapping is 1.5” wide, by .130” thick; contains fungicide, has shape memory retention, is fire retardant
5. Arms: Adjustable armrest height
6. Padding: Standard removable padding – Neck Rest, Side Pads, Full Seat and Back Pad
The 34 ounce healthcare vinyl fabric covering is manufactured to meet the following requirements: DIN 75 200/DIN 53 438; MVSS 302, M2;CAL 117, and Wyzenbeck Heavy Duty Abrasion Test; has an antimicrobial, antibacterial, anti-stain and anti-static finish; Cold crack of -20°C. Polyurethane foam meets CAL 117.

Removable seat and back pads are covered with an 8 ounce soft vinyl which meets CAN2-162 flammability standard for hospital textiles. Polyurethane foam meets CAL 117.
7. Transport Wheels Rear wheels for transporting of chair (while unoccupied)
8. Seat Depth: 17”
9. Seat Height: 18” (Models 100-20 AL, 100-15 AL), 16” (Model 100-10 AL)
10. Seat Width: 20” (Models 100-20 AL, 100-15 AL), 18” (Model 100-10 AL)
11. Weight Capacity: 250 lbs
12. Weight 68 lbs (Model 100-20 AL), 66 lbs (Model 100-15 AL) , 63 lbs (Model 100-10 AL)

All dimensions are ± 0.5”.

5.2 Labels

BRODA uses certain labels to assist caregivers to identify items which permit the operation of the chair's functions.

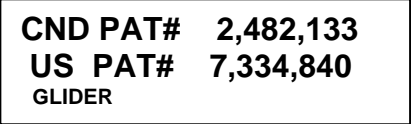
<p>Manufacturer's Label (White)</p>  <p>MADE IN CANADA / FABRIQUE AU CANADA</p> <p>560 Bingham Centre Drive, Kitchener, ON Canada, N2B 3X9 PHONE 1 – 519 746-8080 FAX 1-519-746-8616</p>	<p>Serial Number Label (Gray)</p>  <p>1-800-668-0637</p> <p>PRODUCT # SERIAL # MADE IN CANADA</p>
<p>Transport Wheels Label (White)</p> 	<p>Patent Label (White)</p> 

5.3 BRODA Seating Auto Locking Glider Parts Schematic Drawing and Legend

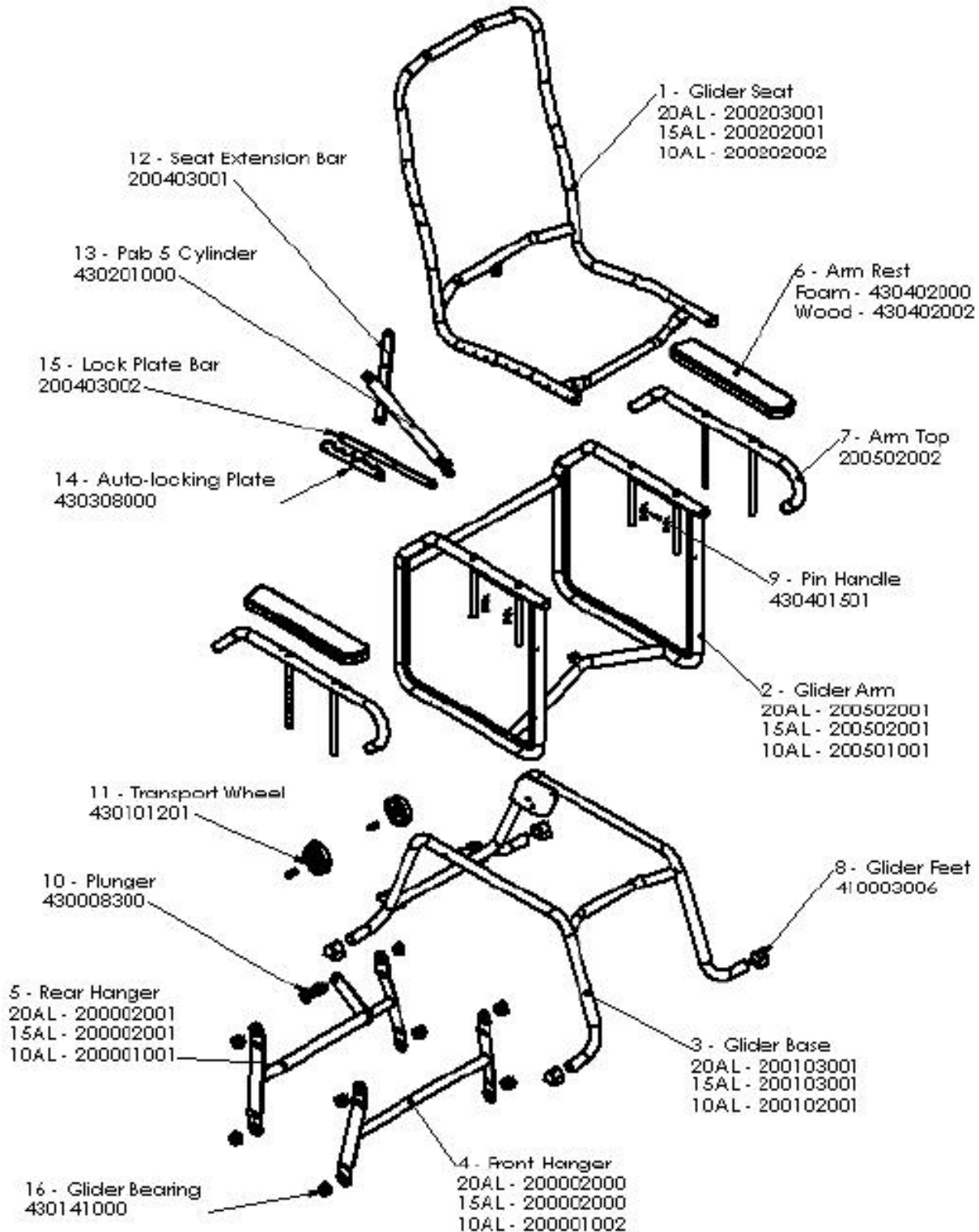

6 WARRANTY

BRODA SEATING **WARRANTY**

BRODA provides a Three Year Warranty on the chair frame, and a One Year Warranty on all other components subject to the following conditions:

No warranty is provided on seat pads or cloth covers.

The chair frames are guaranteed for three years against structural defects or failure. All other parts (except seat pads and cloth covers) including but not limited to strapping, cushions, gas springs and attachments, casters, wheels, brakes and armrests are guaranteed for one year against defects in materials and workmanship based on normal institutional use. The guarantee does not cover malicious or deliberate damage or damage from misuse. The guarantee does not cover use of BRODA chairs in a shower or pool, with the exception of the BRODA Commode/Shower Chair.

Modifications to BRODA products or the use of non-BRODA supplied parts voids the warranty. This warranty does not cover shipping damage (see below).

BRODA will provide new or refurbished parts for installation by the owner at no cost following confirmation by the local BRODA Representative or the BRODA Head Office Customer Service Representative. On request, defective parts must be returned to the factory within thirty days of receipt of the replacement parts by the owner. If the defective parts are not returned to BRODA on request, the owner will bear the cost of the replacement parts on invoice from BRODA.

Warranty does not include on-site labor for the installation of warranty parts or warranty repairs. The owner may return to BRODA products for warranty replacement or repair by shipping items prepaid and insured to the factory. Warranty completed at the factory includes both materials and labor. The decision to repair or replace parts is at the discretion of BRODA. All returns to the factory require prior authorization from BRODA.

BRODA retains the right to make design and application changes without notice. All orders will be filled with BRODA's current models unless otherwise specified by the purchaser.

BRODA chairs are designed for patient mobility, positioning, and comfort in specialty seating, however, the application of BRODA products shall remain the responsibility of the purchaser or user.

This warranty is not transferable.

RETURNS

BRODA Seating will not accept any returns without a prior Returned Goods Authorization Number. Please contact our Head Office Customer Service Representative at 1-800-668-0637 for assistance. Returns must be insured when shipped.

DAMAGED FREIGHT

NOTIFY THE CARRIER OF ANY DAMAGE IMMEDIATELY

It is the responsibility of the person receiving the goods to examine cartons and goods before accepting receipt. Note all damages on the bill of lading and file a claim if necessary. Notify the carrier of any concealed damaged within 48 hours of receipt.

BRODA insures all products for in transit damage, failure to notify the carrier of in transit damage voids both the insurance and the BRODA warranty. If you require assistance, contact our Head Office at 1-800-668-0637.

SALES TAX

Most BRODA products are G.S.T. Zero Rated and Exempt from Canadian Provincial Sales Tax. Purchasers may be required to check with their Provincial or State Tax Office for purchaser tax payment.

Register your warranty at www.brodaseating.com